

POMPOSA

POMPOSA

GRES PORCELLANATO SMALTATO COLORATO IN MASSA
GLAZED PORCELAIN STONEWARE WITH COLOURED BODY
GRÈS CÉRAMÉ ÉMAILLÉ COLORÉ DANS LA MASSE
GLASIERTES FEINSTEINZEUG IN DER MASSE GEFÄRBT
GEGLAZUURD GRES PORCELLANATO DOOR-EN-DOOR GEKLEURD

Definita dal tempo

Ispirata alla pietra dell'omonima chiesa di Modena, la collezione Pomposa unisce passato e presente con un look che reinterpreta colori e texture della materia di origine. Pomposa riscopre e reinterpreta le radici della più iconica tradizione architettonica italiana.

Defined by time. Inspired by the stone found in the church by the same name in Modena (Italy), the Pomposa collection blends past and present featuring a mood that reinterprets the colours and textures of the original material. Pomposa rediscovers and reinterprets the roots of the most iconic Italian architectural tradition.

Définie par le temps. Inspirée de la pierre de l'église homonyme de Modène, la collection Pomposa conjugue passé et présent avec un look qui réinterprète les couleurs et les textures de la matière d'origine. Pomposa redécouvre et réinterprète les racines de la tradition architecturale italienne la plus emblématique.

Von der zeit definiert. Die Kollektion Pomposa ist von der gleichnamigen Kirche in Modena inspiriert und verbindet Vergangenheit und Zukunft mit einem Look, der die Farben und Texturen des ursprünglichen Materials neu interpretiert. Pomposa entdeckt die Wurzeln der ikonischsten Tradition der italienischen Architektur wieder und bietet eine Neuinterpretation.

Door de tijd gevormd. De collectie Pomposa, geïnspireerd door de steen van de gelijknamige kerk van Modena, verenigt verleden en heden aan de hand van een nieuwe interpretatie van de kleuren en texturen die de oorspronkelijke materie kenmerken. Pomposa is de nieuwe interpretatie van de meest iconische Italiaanse architectonische traditie.



pomposa argilla

morbide nuance

Le sfumature morbide di Argilla, simili a quelle del rame antico, dialogano alla perfezione con diversi tipi di materiali, dai metalli al legno ai tessuti. L'irregolarità della superficie e dei bordi, nei formati non rettificati, è esaltata dalle nuance polverose di questa variante, che trova la sua massima espressione in contesti ampi e luminosi.

Delicate nuances. The delicate shades of Argilla, reminiscent of those of ancient copper, pair perfectly with different types of materials, from metals to wood to textiles. The irregular surface and edges, in the non-rectified sizes, is enhanced by the muted nuances of this variant, which is expressed at its best in large and bright contexts.

Nuances douces. Les douces nuances d'Argilla, semblables à celles du cuivre ancien, dialoguent à la perfection avec différents types de matériaux, des métaux au bois et aux textiles. L'irrégularité de la surface et des bords, dans les formats non rectifiés, est mise en valeur par les nuances poussiéreuses de cette variante, qui trouve sa pleine expression dans de vastes contextes lumineux.

Weiche Nuancen. Die weichen Nuancen von Argilla ähneln denen von antikem Kupfer und passen perfekt zu verschiedenen Materialien, wie Metalle, Holz und Textilien. Die Unregelmäßigkeit der Oberflächen und Kanten wird, bei den nicht rektifizierten Formaten, von den staubigen Nuancen dieser Variante betont, die in großen und hellen Umgebungen voll zur Geltung kommt.

Zachte nuances. De zachte nuances van Argilla, vergelijkbaar met antiek koper, zijn ideaal te combineren met uiteenlopende materialen, van metaal tot hout en textiel. De ruwheid van de oppervlakken en randen, en die niet-aangepaste formaten wordt versterkt door de poederachtige tinten van deze variant, die zich perfect thuis voelt in ruime en heldere omgevingen.



Floor outdoor
Argilla 40x40 - 16"x16" R11



Floor
Argilla 20x20 - 8"x8" / Dec Mix 20x20 - 8"x8"



Floor
Argilla 40x60,8 - 16" x24"

Wall
Argilla 20x40 - 8" x16"



Floor
Argilla 20x40 - 8" x16" / 40x60,8 - 16" x24"



Floor
Argilla 20x20 - 8"x8" / 20x40 - 8"x16" / 40x40 - 16"x16"

pomposa mineral

Essenza di pietra

Essenza di pietra. La variante Mineral enfatizza l'irregolarità e il colore della pietra grezza invecchiata. Un grigio-beige mite dal mood urbano che esalta anche gli arredi più audaci. Questa soluzione cromatica, raffinata ed elegante, apre nuove prospettive progettuali a spazi indoor e outdoor, che ritrovano la loro essenzialità.

Stone essence. The Mineral variant accentuates the irregularity and colour of aged rough stone. A mellow greyish-beige featuring an urban vibe that enhances even the most daring of furnishings. This refined and elegant chromatic solution opens up new perspectives in the design of indoor and outdoor spaces, which rediscover their essential nature.

Essence de pierre. La variante Mineral souligne l'irrégularité et la couleur de la pierre brute vieillie. Une nuance gris-beige légère à l'esprit urbain qui sublime même les décorations les plus audacieuses. Cette solution chromatique, raffinée et élégante, ouvre de nouvelles perspectives de projets aux espaces intérieurs et extérieurs qui retrouvent toute leur essentialité.

Steinessenz. Die Variante Mineral betont die Unregelmäßigkeit und die Farbe des gealterten Rohsteins. Ein sanftes Grau-Beige mit städtischem Charakter hebt auch die mutigsten Einrichtungen in den Vordergrund. Diese raffinierte und elegante chromatische Lösung bietet den Indoor- und Outdoor-Projekten neue Perspektiven und erstattet ihnen ihre Wesentlichkeit zurück.

Steen in hart en ziel. De variant Mineral versterkt de onregelmatigheden en de kleur van ruwe steen die de tand des tijds doorstaan heeft. Een mild grijs-beige met urban mood die ook de meest gewaagde inrichtingen verheft. Deze geraffineerde en elegante kleuroplossing geeft nieuwe mogelijkheden voor de minimalistische inrichting van onze ruimten indoor en outdoor.





Floor
Mineral 40x40 - 16"x16"

Wall
Mineral 20x40 - 8"x16" / Dec Mix 20x20 - 8"x8"



Floor
Mineral 40x60,8 - 16"x24"



Floor
Mineral 40x40 - 16"x16" / 20x20 - 8"x8" / Dec Mix 20x20 - 8"x8"



Floor
Mineral 20x40 - 8"x16"

Floor Indoor
Mineral Modulare 39

Wall
Mineral Dec Mix 20x20 - 8"x8"

Floor Outdoor
Mineral 40x60,8 - 16"x24" R11



pomposa ambra

spazi di luce

20

Spazi di luce. Ambra è una tonalità dorata calda che dona luce e vitalità agli ambienti e fa della versatilità il suo punto di forza. Come per le altre colorazioni della gamma, le possibilità di posa modulare, a lisca o con la variante decoro, offrono diverse opportunità di design, per spazi accoglienti dalla grande potenza evocativa.

Bright space. Ambra is a warm golden shade that bestows light and vitality to environments and whose strength is its versatility. As with the other colours in the range, the installation layout options of modular, herringbone or with decoration variant, offer different design opportunities, for welcoming spaces with great evocative intensity.

Espaces lumineux. Ambra est une teinte chaude et dorée qui apporte lumière et vitalité aux espaces et fait de la polyvalence son point fort. Tout comme pour les autres couleurs de la gamme, les possibilités de pose modulaire, à bâtons rompus ou avec la variante décor, offrent plusieurs opportunités de design, pour des espaces accueillants fortement évocateurs.

Lichträume. Ambra ist ein warmer goldener Farbton, der den Umgebungen Licht und Vitalität verleiht und aus Vielseitigkeit seine Stärke macht. Wie für die anderen Farben des Sortiments bieten die Verlegungsarten modular, Fischgrät, oder mit Dekor-Variante verschiedene Design-Möglichkeiten für gemütliche Räume von großer Ausdruckskraft.

Heldere ruimten. Ambra is een warme goudtint die licht en vitaliteit verleent aan het interieur en deze veelzijdigheid is dan ook de kracht van deze variant. Net zoals de andere nuances van het gamma, biedt de mogelijkheid van een plaatsing in modules, met visgraatmotief of decoratie, eendeloze designoplossingen, voor aangename ruimten die kracht uitstralen.



21



Floor
 Ambra 40x40 - 16"x16" / Dec Mix 20x20 - 8"x8"



Floor
 Ambra 20x40 - 8"x16" / 20x20 - 8"x8"
Wall
 Ambra Dec Mix 20x20 - 8"x8"



Floor
 Ambra 40x60,8 - 16"x24"



Floor
 Ambra Modulare 39



Floor
Ambra 40x40 - 16"x16" / 40x60,8 - 16"x24"





28

pomposa siena

futuro e tradizione

29

Siena interpreta la pietra originaria con un marrone-rosso vibrante, dall'inconfondibile rimando al saper fare italiano. Il contrasto cromatico, dato dalla punta di nero e dagli inserti chiari, lo rende un colore versatile, adatto sia ad ambienti classici che a spazi più contemporanei.

Future and tradition. Siena renders the original stone featuring a vibrant reddish-brown, with an unmistakable reference to Italian mastership. The chromatic contrast, given by the hint of black and the light inserts, makes it a versatile colour, suitable for both classic environments and more contemporary spaces.

Futur et tradition. Siena interprète la pierre d'origine par une nuance marron-rouge vibrante, avec une incontestable évocation du savoir-faire italien. Le contraste chromatique, porté par la touche de noir et par les inserts clairs, en fait une couleur polyvalente, qui s'adapte aux espaces classiques ou plus contemporains.

Zukunft und Tradition. Siena interpretiert den Originalstein in einem vibrierenden Braun-Rot, das unverkennbar auf das italienische Savoir-faire hinweist. Durch den chromatischen Kontrast, den der Hauch von Schwarz und die hellen Einleger schaffen, ist die Farbe vielseitig und sowohl für klassische Umgebungen als auch für modernere Räume geeignet.

Toekomst en traditie. Siena kijkt op een nieuwe manier naar de oorspronkelijke steen in een levendige bruin-rode kleur, waarbij de Italiaanse know-how centraal staat. Het kleurcontrast, dankzij de zwarte toetsen en de lichte inserts, wordt zo een veelzijdige keuze die zowel voor meer klassieke of eerder hedendaagse interieurs geschikt is.



Floor
 Siena 20x40 - 8"x16" / 40x40 - 16"x16"



Floor
 Siena 40x40 - 16"x16"



Floor
Siena 40x60,8 - 16"x24"



Floor
Siena 20x20 - 8"x8"



34

35

Floor outdoor
Siena Modulare 39 R11

pomposa vellum

Isla Tiles propone tutte le varianti colore anche nei formati 80x80 e 60x60 rettificati che annullano la percezione delle fughe. Disponibile solo in queste dimensioni, la finitura lappata Vellum, latino per pergamena, ricrea l'usura da calpestio mettendo in risalto la lucentezza e il realismo della superficie levigata. Una finitura dal suggestivo impatto visivo che fa rivivere la sua ispirazione originaria.

The past lives again. Isla Tiles also offers all the colour variants in the rectified 80x80 and 60x60 sizes which eliminate the awareness of joints. Available only in these sizes, the lapped Vellum finish - Latin for parchment - renders the wear and tear of footfall, highlighting the shine and realism of the polished surface. A visually evocative finish that brings its original inspiration back to life.

Le passé renaît. Isla Tiles propose toutes les variantes de couleur, y compris dans les formats 80x80 et 60x60 rectifiés, qui annulent la perception des joints. Disponible uniquement dans ces dimensions, la finition polie Vellum, parchemin en latin, recrée l'usure du piétinement en valorisant le brillant et le réalisme de la surface polie. Une finition à l'impact visuel saisissant qui fait revivre son inspiration d'origine.

Die Vergangenheit lebt wieder auf. Isla Tiles bietet alle Farbvarianten auch in den rektifizierten Formaten 80x80 und 60x60, bei denen die Fugen nicht wahrzunehmen sind. Nur in diesen Größen gibt es das geläppte Finish Vellum, der lateinische Name für Pergament, das den Begehungsabrieb nachgestaltet und den Glanz und Realismus der geglätteten Oberfläche betont. Dieses eindrucksvoll wirkende Finish ruft die ursprüngliche Inspiration wach.

Het verleden herhalen. Isla Tiles stelt alle kleurvarianten voor ook in de aangepaste formaten 80x80 en 60x60, zodat de voegen niet te zien zijn. De gepolijste afwerking van Vellum is alleen met deze afmetingen beschikbaar. De naam is Latijn voor perkament en deze tegel bootst de slijtage van de vloer na en zet de glans en het realisme van het gladde oppervlak in de kijker. Deze afwerking heeft een suggestieve visuele aantrekkingskracht die hulde brengt aan de oorspronkelijke inspiratie.



il passato rivive



Siena

Floor indoor
80x80 - 32"x32" Vellum Rett

Floor outdoor
80x80 - 32"x32" R11 20 mm Rett



Ambra

Floor
80x80 - 32"x32" Vellum Rett

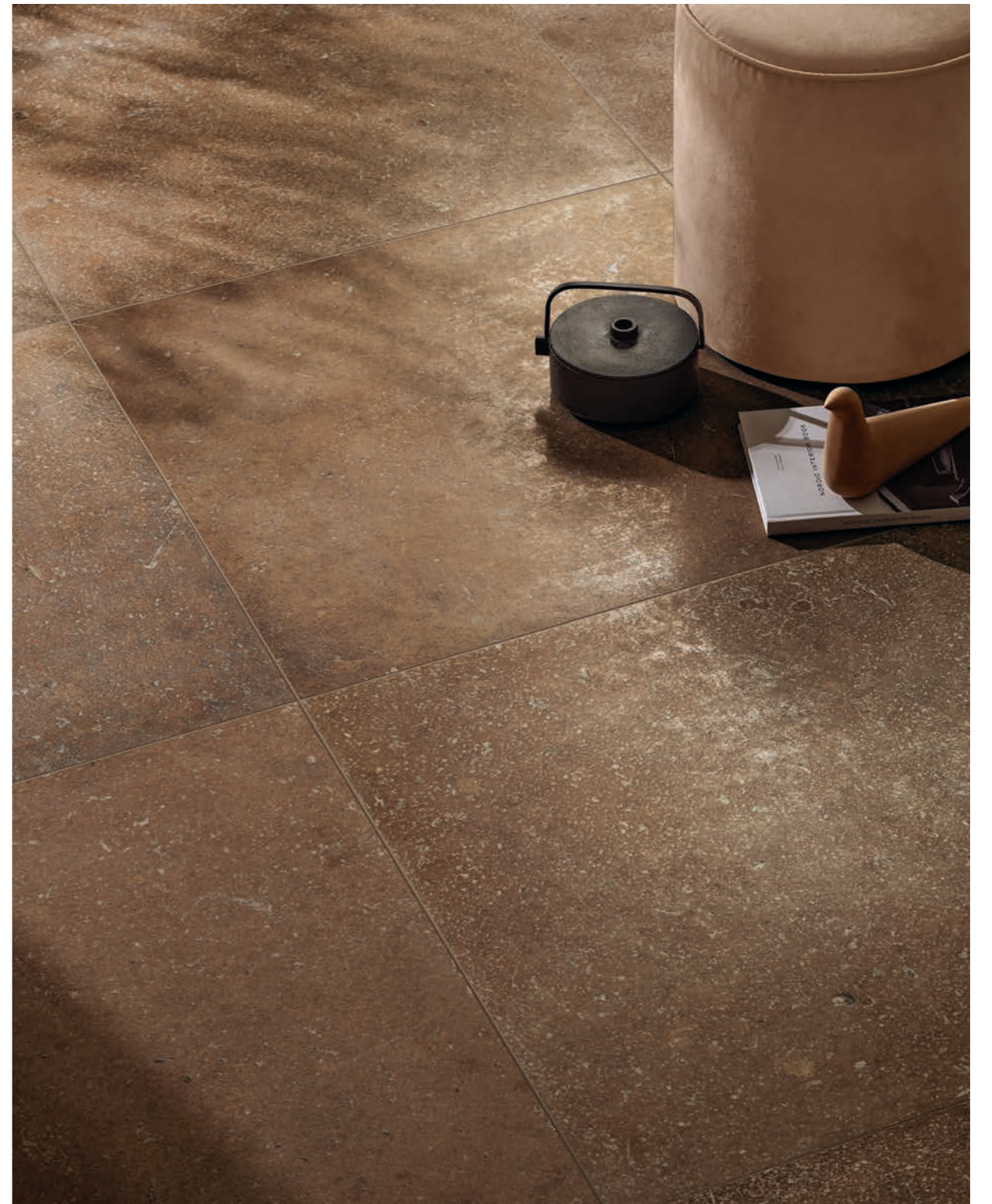

Ambra

Floor
80x80 - 32"x32" Vellum Rett



Argilla

Floor
60x60 - 24"x24" Vellum Rett

Wall
60x60 - 24"x24" Vellum Rett





Mineral

Floor outdoor
80x80 - 16"x16" R11 20 mm Rett



Mineral

Floor
80x80 - 16"x16" Vellum Rett



ARGILLA

GRES PORCELLANATO SMALTATO COLORATO IN MASSA
 GLAZED PORCELAIN STONEWARE WITH COLOURED BODY
 GRÈS CÉRAMÉ ÉMAILLÉ COLORE DANS LA MASSE
 GLASIERTES FEINSTEINZEUG IN DER MASSE GEFÄRBT
 GEGLAZUURD GRES PORCELLANATO DOOR-EN-DOOR GEKLEURD

FORMATI - SIZES - FORMATS - FORMATE - FORMATEN

1006807 40x60,8 - 16"x32"	4	053	1006803 40x40 - 16"x16"	8	053	1006795 20x20 - 8"x8"	26	053	1006799 20x40 - 8"x16"	13	053	1006827 DEC MIX ARGILLA * 20x20 - 8"x8"	26	086
1006823 40x60,8 - 16"x32" R11	4	053	1006819 40x40 - 16"x16" R11	8	053	1006811 20x20 - 8"x8" R11	26	053	1006815 20x40 - 8"x16" R11	13	053			



ARGILLA VELLUM

1006843 80x80 - 32"x32" Vellum Rett	2	086	1006888 60x60 - 24"x24" Vellum Rett	3	068
1006861 80x80 - 32"x32" R11 20 MM	1	094			

* Soggetti miscelati casualmente nelle scatole / Designs available with each box containing a random mix / Motifs mélangés au hasard dans les boîtes / Die Muster in den Schachteln werden nach den Zufallsprinzip gemischt / De patronen worden willekeurig in dozen gemengd.



MINERAL

GRES PORCELLANATO SMALTATO COLORATO IN MASSA
 GLAZED PORCELAIN STONEWARE WITH COLOURED BODY
 GRÈS CÉRAME ÉMAILLÉ COLORE DANS LA MASSE
 GLASIERTES FEINSTEINZEUG IN DER MASSE GEFÄRBT
 GEGLAZUURD GRES PORCELLANATO DOOR-EN-DOOR GEKLEURD

9,5 mm
80x80
60x60

10 mm
▲ "3/8"

20 mm
▲ "13/16"

R10 CLASS B

R11 CLASS C

V3

V4

FORMATI - SIZES - FORMATS - FORMATE - FORMATEN

1006808
40x60,8 - 16"x32"
4 053

1006804
40x40 - 16"x16"
8 053

1006800
20x40 - 8"x16"
13 053

1006812
20x20 - 8"x8" R11
26 053

1006816
20x40 - 8"x16" R11
13 053

1006796
20x20 - 8"x8"
26 053

1006824
40x60,8 - 16"x32" R11
4 053

1006820
40x40 - 16"x16" R11
8 053

1006816
20x40 - 8"x16" R11
13 053

1006828 DEC MIX MINERAL *
20x20 - 8"x8"
26 086



MINERAL VELLUM

1006844
80x80 - 32"x32" Vellum Rett
2 086

1006862
80x80 - 32"x32" R11 20 MM
1 094

1006889
60x60 - 24"x24" Vellum Rett
3 068











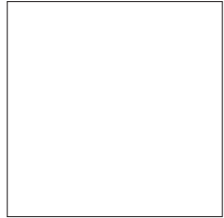
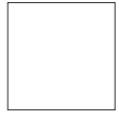

* Soggetti miscelati casualmente nelle scatole / Designs available with each box containing a random mix / Motifs mélangés au hasard dans les boîtes
 Die Muster in den Schachteln werden nach den Zufallsprinzip gemischt / De patronen worden willekeurig in dozen gemengd.



AMBRA





GRES PORCELLANATO SMALTATO COLORATO IN MASSA
 GLAZED PORCELAIN STONEWARE WITH COLOURED BODY
 GRÈS CÉRAME ÉMAILLÉ COLORE DANS LA MASSE
 GLASIERTES FEINSTEINZEUG IN DER MASSE GEFÄRBT
 GEGLAZUURD GRES PORCELLANATO DOOR-EN-DOOR GEKLEURD

FORMATI - SIZES - FORMATS - FORMATE - FORMATEN

 1006806 40x60,8 - 16"x32"	 1006802 40x40 - 16"x16"	 1006794 20x20 - 8"x8"	 1006810 20x20 - 8"x8" R11	 1006798 20x40 - 8"x16"	 1006814 20x40 - 8"x16" R11	 1006826 DEC MIX AMBRA * 20x20 - 8"x8"
						

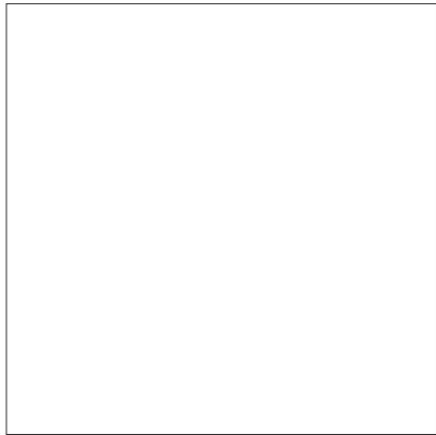
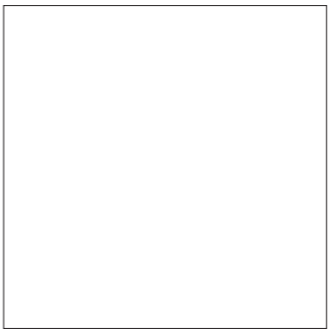
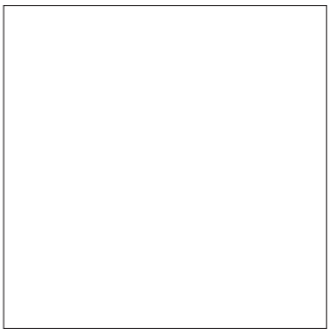

AMBRA VELLUM

 1006842 80x80 - 32"x32" Vellum Rett	 1006860 80x80 - 32"x32" R11 20 MM	 1006887 60x60 - 24"x24" Vellum Rett
		







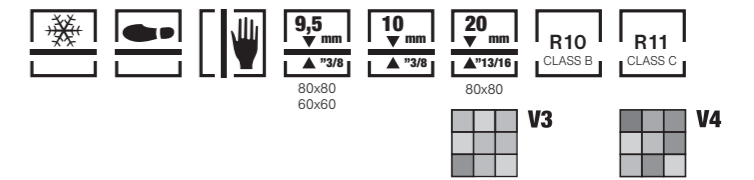



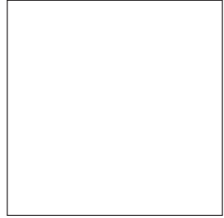

* Soggetti miscelati casualmente nelle scatole / Designs available with each box containing a random mix / Motifs mélangés au hasard dans les boîtes / Die Muster in den Schachteln werden nach den Zufallsprinzip gemischt / De patronen worden willekeurig in dozen gemengd.

SIENA

GRES PORCELLANATO SMALTATO COLORATO IN MASSA
 GLAZED PORCELAIN STONEWARE WITH COLOURED BODY
 GRÈS CÉRAME ÉMAILLÉ COLORE DANS LA MASSE
 GLASIERTES FEINSTEINZEUG IN DER MASSE GEFÄRBT
 GEGLAZUURD GRES PORCELLANATO DOOR-EN-DOOR GEKLEURD





FORMATI - SIZES - FORMATS - FORMATE - FORMATEN

			
1006809 40x60,8 - 16"x32"	1006805 40x40 - 16"x16"	1006797 20x20 - 8"x8"	
			
1006825 40x60,8 - 16"x32" R11	1006821 40x40 - 16"x16" R11	1006801 20x40 - 8"x16"	1006829 DEC MIX SIENA * 20x20 - 8"x8"
			
		1006817 20x40 - 8"x16" R11	
			

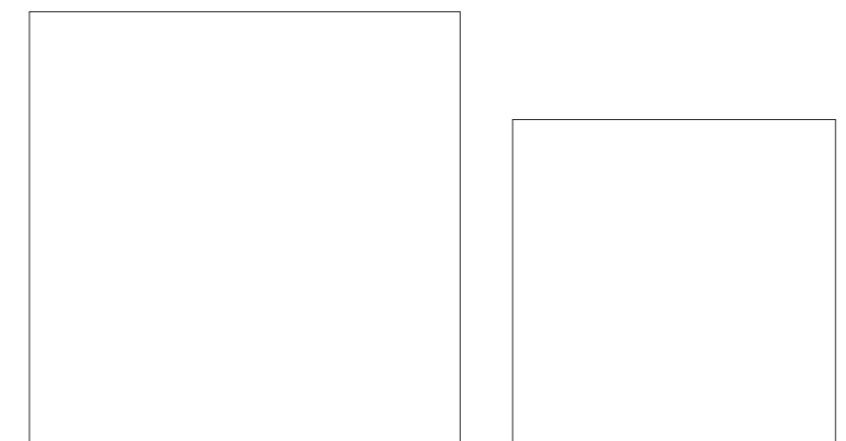
SIENA VELLUM



1006845 80x80 - 32"x32" Vellum Rett		1006890 60x60 - 24"x24" Vellum Rett	
1006863 80x80 - 32"x32" R11 20 MM			

* Soggetti miscelati casualmente nelle scatole / Designs available with each box containing a random mix / Motifs mélangés au hasard dans les boîtes / Die Muster in den Schachteln werden nach den Zufallsprinzip gemischt / De patronen worden willekeurig in dozen gemengd.

POMPOSA

GRES PORCELLANATO SMALTATO COLORATO IN MASSA
GLAZED PORCELAIN STONEWARE WITH COLOURED BODY
GRÈS CÉRAMÉ ÉMAILLÉ COLORÉ DANS LA MASSE
GLASIERTES FEINSTEINZEUG IN DER MASSE GEFÄRBT
GEGLAZUURD GRES PORCELLANATO DOOR-EN-DOOR GEKLEURD

SCHEMI DI POSA

LAYING SKETCH - SCHÉMAS DE POSE - MODULVERLEGUNGSBEISPIELE - LEGSYSTEMEN

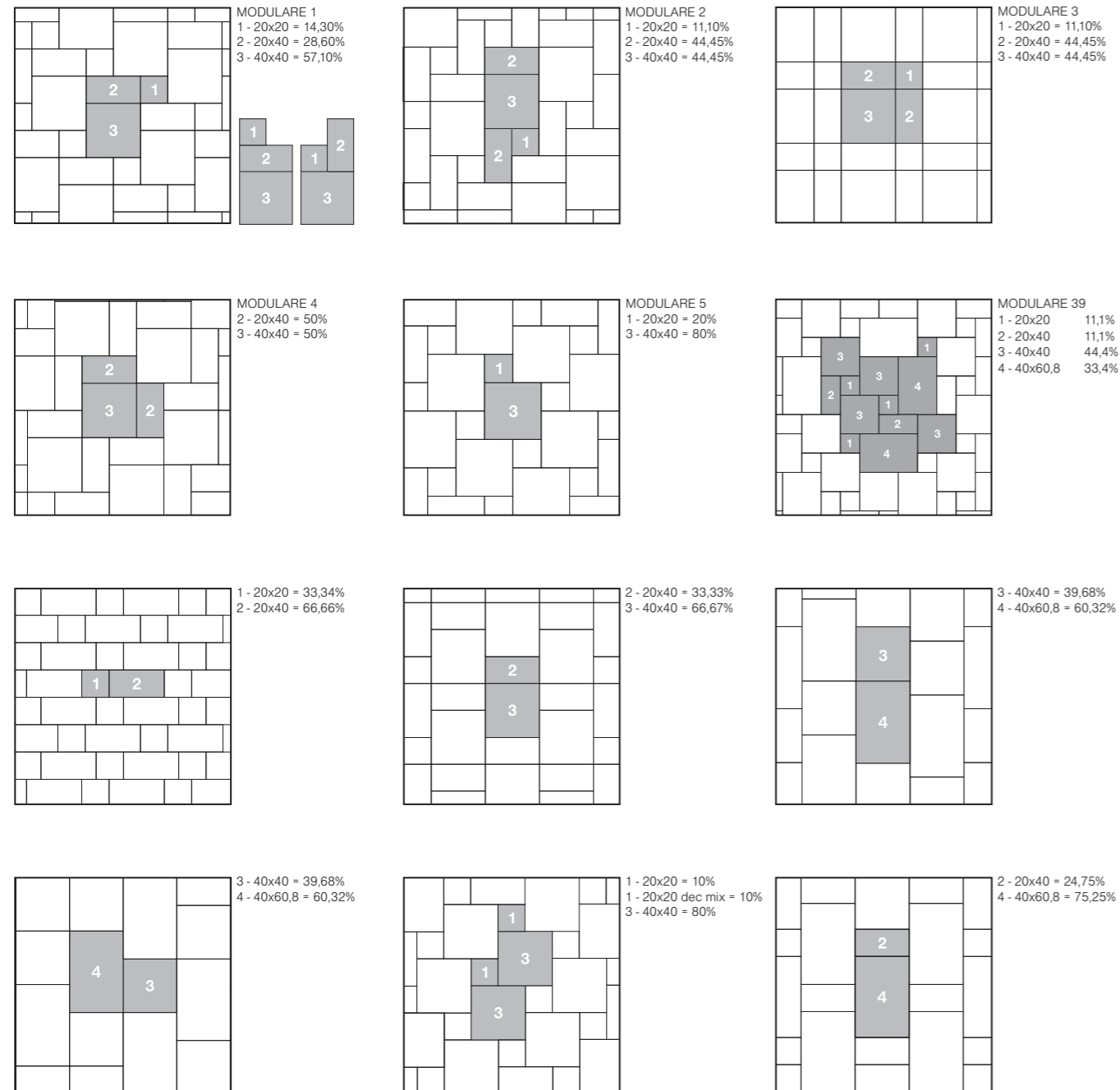

54

IMBALLI

PACKING TABLE - TABLEAU DES EMBALLAGES - VERPACKUNGS TABELLE - VERPAKKINGEN

FORMATO SIZE	SCATOLA - BOX			PALLET		
	Pezzi - Pieces	m ²	KG	Scatole - Boxes	m ²	KG
80x80 - 32"x32" Vellum Rettificato	2	1,28	27,00	48	61,44	1312
60x60 - 24"x24" Vellum Rettificato	3	1,08	22,80	40	43,20	928
40x60,8 - 16"x32" / 40x60,8 - 16"x32" R11	4	0,97	21,50	60	58,20	1306
40x40 - 16"x16" / 40x40 - 16"x16" R11	8	1,28	26,50	48	61,44	1288
20x40 - 8"x16" / 20x40 - 8"x16" R11	13	1,04	20,30	54	56,16	1112
20x20 - 8"x8" / 20x20 - 8"x8" R11 / Dec Mix	26	1,04	20,30	54	56,16	1112
80x80 - 32"x32" Vellum R11 20 MM	1	0,64	30,50	48	30,70	1484
6,5x40 - 2 ⁹ / ₁₆ "x16" Battiscopa	20	8,00 ml	11,50	-	-	-
7,5x80 - 3"x32" Battiscopa Rettificato	6	4,80 ml	9,00	-	-	-

PEZZI SPECIALI 9,5 MM E 10 MM - SPECIAL PIECES 9,5 MM AND 10 MM

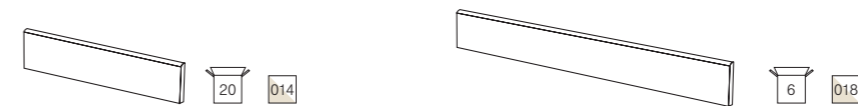

BATTISCOPA 6,5x40 - 2⁹/₁₆"x16"
1006846 AMBRA
1006847 ARGILLA
1006848 MINERAL
1006849 SIENA

BATTISCOPA 7,5x80 - 3"x32" Rett
1006850 AMBRA
1006851 ARGILLA
1006852 MINERAL
1006853 SIENA

55

PEZZI SPECIALI 20 MM - SPECIAL PIECES 20 MM

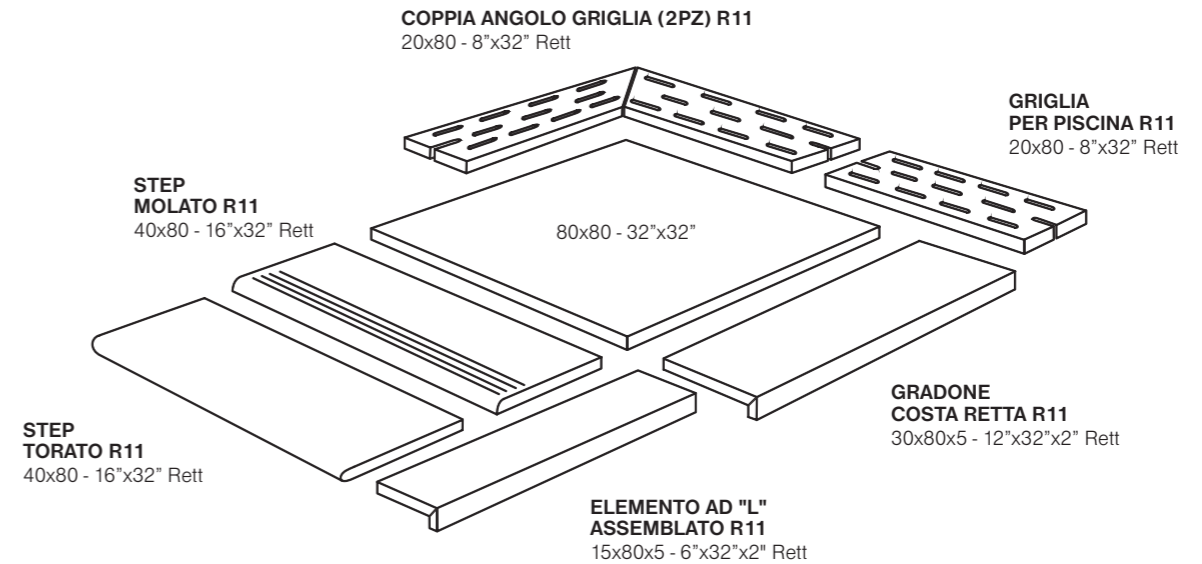

**GRES PORCELLANATO SMALTATO
COLORATO IN MASSA**

GLAZED PORCELAIN STONEWARE WITH COLOURED BODY
GRÈS CÉRAME ÉMAILLÉ COLORÉ DANS LA MASSE
GLASIERTES FEINSTEINZEUG IN DER MASSE GEFÄRBT
GEGLAZUURD GRES PORCELLANATO DOOR-EN-DOOR GEKLEURD

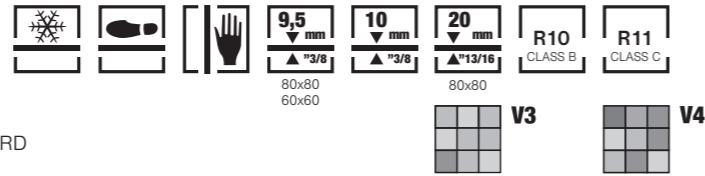

Proprietà fisico chimiche Physical-chemical properties Caracteristiques physiques-chimiques Physische Chemische eigenschaften Fysisch-chemische eigenschappen	Norme Norms Noemes Normen Normen	Valori presvalori prescritti Required values Valeurs exigees Vorgeschriebene werte Vereiste waarde	VELLUM RETT	R11 RETT
Dimensioni Sizes Format Format Afmetingen	ISO 10545-2	Aspetto Superficiale Surface appearance Aspect superficiel Oberflächenbeschaffenheit	≥ 95%	≥ 95%
		Lunghezza e larghezza Length and width Longueur et largeur Länge und Breite Lengte en breedte	± 0,5% ± 2 mm	± 0,5% ± 1,5 mm
		Rettilineità spigoli Linearity Rectitude de l'angularité Kantengeradheit Rechtlijnigheid van de hoeken	± 0,5% ± 2 mm	± 0,5% ± 1,5 mm
		Spessore Thickness Épaisseur Stärke Dikte	± 5% ± 0,5 mm	± 5% ± 0,5 mm
		Ortogonalità Wedging Orthogonalité Rechtwinkligkeit Rechthoekigheid	± 0,3% ± 2 mm	± 0,5% ± 1,5 mm
		Planarità Warpage Planéité Ebenflächigkeit Vlakheid	± 0,5% ± 2 mm	± 0,5% ± 1,5 mm
Resistenza al gelo Frost resistance Résistance au gel Froständigkeit Vorstandigkeit	ISO 10545-12	Resistente Resistant Résistant Widerstandsfähigkeit Bestendig	Resistente Resistant Résistant Widerstandsfähigkeit Bestendig	
Assorbimento d'acqua Water absorption Absorption d'eau Wasseraufnahme Waterabsorptie	ISO 10545-3	≤ 0,1% Gruppo Bla GL	E ≤ 0,1% Bla	
Resistenza a flessione e forza di rottura Modulus of rupture and breaking strength résistance à la flexion et force de rupture Biegefestigkeit und Bruchlast Buigvastheid en breaksterkte	ISO 10545-4	S ≥ 1300 N	S ≥ 1300 N	
		R ≥ 35 N/mm ²	R ≥ 35 N/mm ²	
Resistenza agli sbalzi termici Thermal shocks resistant Résistance aux variations thermiques Temperaturwechselbeständigkeit Weerstand tegen temperatuurschokken	ISO 10545-9	Resistente Resistant Résistant Widerstandsfähigkeit Bestendig	Resistente Resistant Résistant Widerstandsfähigkeit Bestendig	
Resistenza alla abrasione della superficie di piastrelle smaltate Resistance to surface abrasion of glazed tiles Résistance à l'abrasion de la surface des carreaux émaillés Widerstand gegen Abrieb der Oberfläche der glasierten Fliesen Slijtvastheid van het oppervlak van geglaazuurde tegels	ISO 10545-7	Classe 3-4 Class 3-4 Classe 3-4 Gruppe 3-4 Klasse 3-4	Classe 3-4 Class 3-4 Classe 3-4 Gruppe 3-4 Klasse 3-4	
Coefficiente di dilatazione termica lineare (50°/400°) Linear thermal expansion coefficient (50°/400°) Dilatation thermique linéaire (50°/400°) Lineare Wärmeausdehnung (50°/400°) Lineaire thermische uitzettingscoëfficiënt (50°/400°)	ISO 10545-8	Metodo disponibile Test method available Méthode disponible Verfügbares Verfahren Beschikbare met	Metodo disponibile Test method available Méthode disponible Verfügbares Verfahren Beschikbare met	
Durezza della Superficie Surface resistance Dureté de la surface Ritzhärte deo Oberfläche Oppervlaktehardheid	EN 101	Mohs ≥ 6	Mohs ≥ 5	Mohs ≥ 6
Resistenza all'attacco chimico (tranne acido fluoridrico) Resistance to chemical attack (except hydrofluoric acid) Résistance à l'attaque chimique (sauf acide fluoridrique) Säure-und Laugenbeständigkeit (außer Flußsäure) Chemische resistentie (behalve waterstofzuur)	ISO 10545-13	Classe A-LA-HA Class A-LA-HA Classe A-LA-HA Gruppe A-LA-HA Klasse A-LA-HA	Classe A-LA Class A-LA Classe A-LA Gruppe A-LA Klasse A-LA	Classe A-LA-HA Class A-LA-HA Classe A-LA-HA Gruppe A-LA-HA Klasse A-LA-HA
Resistenza alle macchie Resistance to staining Résistance aux taches Fleckbeständigkeit Vlekbestendigheid van geglaazuurde tegels	ISO 10545-14	Classe 5 Class 5 Classe 5 Gruppe 5 Klasse 5	Classe 5 Class 5 Classe 5 Gruppe 5 Klasse 5	
Coefficiente di attrito Coefficient of friction Coefficient de frottement Reibungskoeffizient Gemiddelde wrijvingscoëfficiënt	DIN 51130	R10	R11	R11
Resistenza alla scivolosità. Coefficiente di attrito medio Skid resistance. Average coefficient of friction Résistance au glissement. Coefficient de frottement moyen Rutschfestigkeit. Mittlerer Reibungswert Slipweerstand. Gemiddelde wrijvingscoëfficiënt	DIN 51097	Classe B Class B Classe B Gruppe B Klasse B	Classe C Class C Classe C Gruppe C Klasse C	Classe C Class C Classe C Gruppe C Klasse C
	B.C.R.A. DCOF Acu Test	M ≥ 0,40 M ≥ 0,42	-	M ≥ 0,40 M ≥ 0,42
Variazione cromatica Colour shading Variations chromatiques Chromatische Abweichungen Kleurvariatie		V3-V4	V3-V4	



Prima edizione: Febbraio 2024
Coordinamento: Ufficio Marketing
© Copyright 2024 Gruppo Romani S.p.A.

